

(Following Paper ID and Roll No. to be filled in your Answer Book)

PAPER ID : 1118

Roll No.

--	--	--	--	--	--	--	--	--	--

B. Tech.

(Semester-I) Theory Examination, 2012-13

ENGINEERING MECHANICS

Time : 3 Hours]

[Total Marks : 100

Note : Attempt questions from each Section as per instructions.

Section-A

Attempt *all* parts of this question. Each part carries 2 marks. $2 \times 10 = 20$

- (a) Define the following terms :
- Coplanar forces
 - Concurrent forces.
- (b) Explain free body diagram with example.
- (c) State Varignon's theorem.

- (d) Give the methods used to analyze plane truss.
- (e) List out the different types of friction. What is coefficient of static friction?
- (f) Give centroid of quarter circle arc.
- (g) Define radius of gyration with respect to x -axis of an area.
- (h) Explain the difference between kinematics and kinetics.
- (i) What do you mean by general plane motion?
- (j) Define mechanical advantage.

Section-B

Attempt any *three* parts of this question. Each question carries 10 marks. $10 \times 3 = 30$

2. (a) (i) A system of concurrent force is as shown in Fig. 1. Find the net components along X and Y directions.

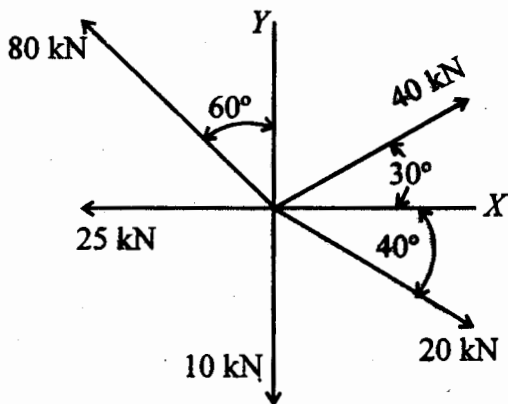

Fig. 1

- (ii) A block is supported on a hinge at A and subjected to three forces, 9 kN , 6 kN and P as shown in Fig. 2. Neglecting the weight of the block determine the force P and the reaction at the hinge.

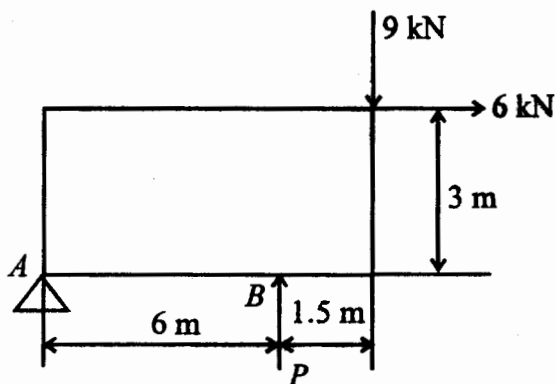

Fig. 2

- (b) A ladder 6 m long weighing 300 N is resting against a wall at an angle of 60° to the horizontal plane as shown in Fig. 3. A man weighing 750 N climbs the ladder from position B towards A . At what position along the ladder from the bottom of the ladder does he induce slipping? The coefficient of friction for both the wall and the ground with the ladder is 0.2.

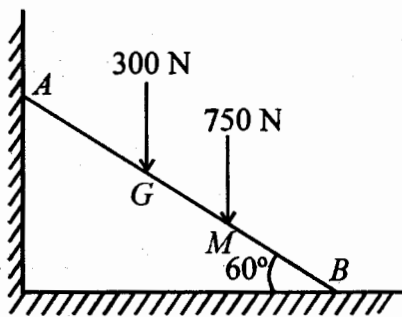

Fig. 3

- (c) Find the moment of area of the diagram shown in Fig. 4, about its centroidal axes.

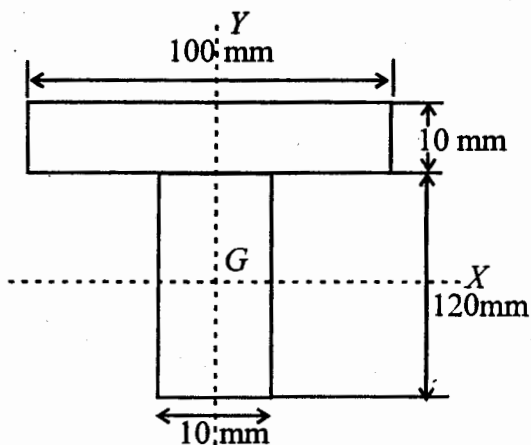

Fig. 4

- (d) A rectilinear motion of motor car starting from rest is governed by the equation $a = 8/1.5 v + 2$, where a is the acceleration in m/sec^2 and v is velocity in m/sec . at any instant. Find the distance moved and the time taken by the car to attain a velocity of 8 m/sec .
- (e) A 30 kg. block shown in Fig. 5 is imparted a velocity of 10 m/sec . The coefficient of kinetic friction between the block and the floor is 0.28. Determine the distance covered by the block before it comes to

rest and also time required for the box to come to rest.

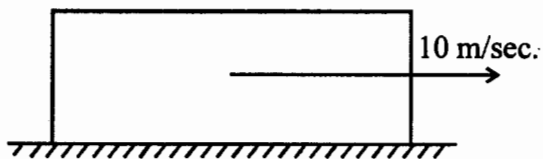

Fig. 5

Section-C

Attempt *all* questions of this Section. Each question carries 10 marks. $10 \times 5 = 50$

3. Attempt any two question parts : $5 \times 2 = 10$

- State the Newton's laws of motion.
- Explain the principle of transmissibility in detail.
- Find the moment of sum of forces shown in Fig. 6 about point A.

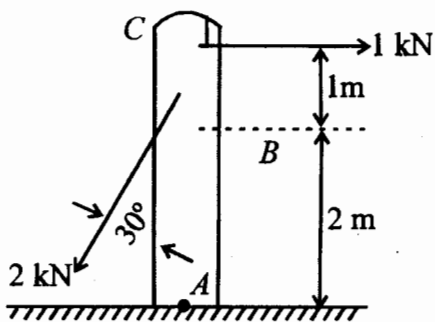

Fig. 6

4. Attempt any one question part : $10 \times 1 = 10$

(a) Explain :

(i) Coefficient of friction

(ii) Angle of friction

(iii) Angle of repose.

(b) Determine the force in all the members of the truss shown in Fig. 7.

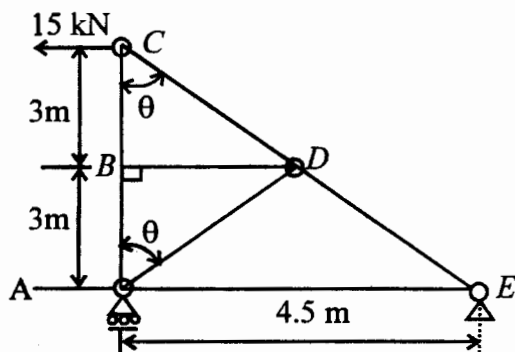

Fig. 7

5. Attempt any one question part : $10 \times 1 = 10$

(a) Determine the centroid of semicircular area of radius r using method of integration.

(b) Explain :

(i) Parallel axes theorem

(ii) Perpendicular axes theorem.

6. Attempt any one question part : $10 \times 1 = 10$

- (a) Explain plane rectilinear motion of rigid body.
- (b) Explain plane curvilinear motion of rigid body.

7. Attempt any two question parts : $5 \times 2 = 10$

- (a) Explain D'Alembert's principle and dynamic equilibrium.
- (b) Explain principle of virtual work.
- (c) In a lifting machine an effort of 98.2 N raised a load of 1000 N and an effort of 498.2 N raised a load of 6000 N. By using law of machine, find what effort is required to lift a load of 10000 N. Find also the maximum mechanical advantage.