

(Following Paper ID and Roll No. to be filled in your Answer Books)

Paper ID : 2289964

Roll No.

--	--	--	--	--	--	--	--	--	--

## B.TECH

Regular Theory Examination (Odd Sem-I), 2016-17

### BASIC ELECTRICAL ENGINEERING

*Time : 3 Hours*

*Max. Marks : 70*

**Note:** Attempt all sections. Answer any data if found missing.

#### SECTION - A

1. Attempt all the following parts. (7×2=14)
  - a) Give two comparison between unilateral and bilateral elements
  - b) Give two limitation of Thevenin's theorem.
  - c) What will be the RMS value of voltage for  $v = 416 \sin \omega t$  waveform.

**REE - 101**

- d) In case two wattmeters are having same reading in a two wattmeter method of power measurement what will be the power factor of the circuit?
- e) What do you mean by back emf in dc motor.
- f) Write emf equation of single phase transformer.
- g) Give two causes of Low power factor.

**SECTION - B**

2. Attempt any three from the following: (3×7=21)

- a) State and Explain Kirchoff's Law. What are the limitations and applications of Kirchoff's Law in circuit theory explain.
- b) What do you understand by "Series Resonance" and "Parallel Resonance"? What are the application of tank circuits?
- c) Derive relation between line and phase values in delta connected 3-phase balance system. A 3 phase voltage source has a phase voltage of 120V and

**REE - 101**

supplies star connected load having impedance of  $24 + j36 \Omega$  per phase.

Calculate

- i) Line Voltage
- ii) Line current
- iii) Total 3-phase power supplied to the load.
- d) Explain the working of induction type of single phase energy meter with neat diagrams.
- e) A 120 V dc shunt motor having an armature circuit resistance of  $0.2 \Omega$  and field circuit resistance of  $60 \Omega$ , draw a line current of 40 A at full load. The brush voltage drop is 3V and rated full load speed is 1800 rpm. Calculate
  - i) The speed at half load
  - ii) The speed at 125% of full load.

SECTION - C

Attempt any five questions from the following  
(5×7=35)

3. Using mesh analysis, find the currents  $I_1, I_2$  and  $I_3$  in the following circuit of Fig.1

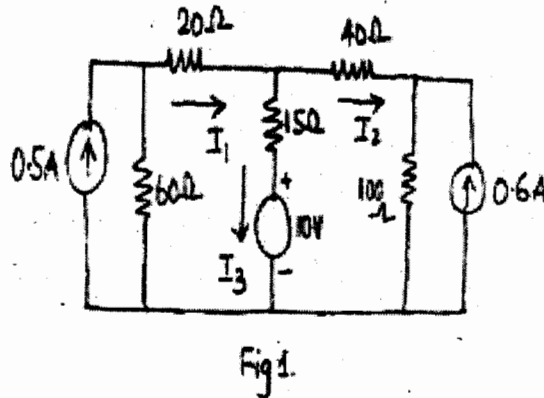

4. A series ac circuit has a resistance of  $15\Omega$  and inductive reactance of  $10\Omega$ . Calculate the value of a capacitor which is connected across this series combination so that system has unit power factor. The frequency of ac supply is 50Hz

5. A 1-phase 250/500 V transformer gave the following results.

Open circuit test 250V, 1A, 80W (LV side)

Short circuit test 20V, 12A, 100W (H.V.Side)

Calculate the equivalent circuit parameters and show them on an equivalent circuit.

6. i) Explain why the hysteresis loss and eddy current loss occur in a transformer. Explain how these losses can be reduced in a transformer. (4)
- ii) What do you understand by the efficiency of a transformer? Deduce the condition for maximum efficiency. (3)
7. i) Explain B-H loop for magnetic circuit. (3)
- ii) An iron ring 10 cm mean diameter is made of round iron rod 1.5cm in diameter of relative permeability of 900 and has an air gap of 5mm in length. It has a winding of 400 turns. If the current through winding is 3.4 amp. Determine:

- a) mmf
  - b) Flux in the ring
  - c) flux density in the ring
  - d) Total reluctance of the circuit.
8. Explain three wattmeter method to measure 3- $\phi$  power in a Y connected load. Derive the phase angle in terms of wattmeter reading and also draw phasor diagram also.
9. a) Explain the speed-torque characteristics of dc shunt and series motors.
- b) Explain why a synchronous motor does not develop starting torque.
- c) Explain the working principle of three phase induction motor.

10. The induced emf between the slip-ring terminals of 3-phase induction motor, when the rotor is stand still is 100V. The rotor windings are star connected and have resistance and stand still reactance of  $0.05 \Omega$  and  $0.1 \Omega$  per phase respectively. Calculate the rotor current and phase difference between rotor voltage and current at 4% slip.