



Roll No:

--	--	--	--	--	--	--	--	--	--	--	--	--	--	--	--	--	--	--	--

B.TECH
(SEM I) THEORY EXAMINATION 2020-21
BASIC OF ELECTRICAL ENGINEERING

Time: 3 Hours

Total Marks: 100

Note: 1. Attempt all Sections. If require any missing data; then choose suitably.

SECTION A

1. Attempt all questions in brief. 2 x 10 = 20

Qno.	Question	Marks	CO
a.	Define ideal voltage and current source.	2	1
b.	Define Active and Passive Elements.	2	1
c.	Define Form factor and Peak Factor.	2	2
d.	Classify the losses in transformer.	2	3
e.	Explain True power, reactive power and Apparent power	2	3
f.	What is meant by the term speed regulation	2	4
g.	Why transformer is not used on DC	2	4
h.	Define the term slip	2	4
i.	Write down the application of Synchronous Motor.	2	4
j.	Write application of Single Phase Induction Motor.	2	4

SECTION B

2. Attempt any three of the following:

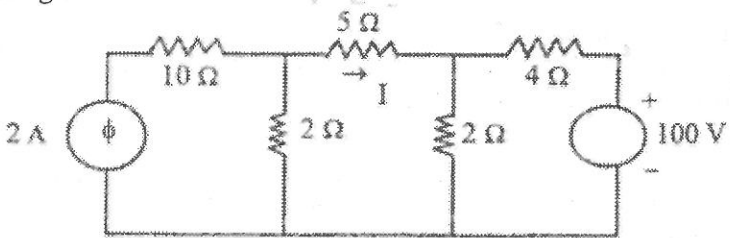
Qno.	Question	Marks	CO
a.	Apply mesh analysis , obtain the current through 5 ohm resistance in the following circuit 	10	1
b.	Obtain equivalent Star from Delta in Star-Delta Transformation	10	1
c.	Derive expression for average value and RMS value of Half wave rectifier voltage output.	10	2
d.	Why Single Phase induction motor is not self starting. What are different methods to make self starting. Explain one of them	10	3
e.	A balanced star connected load of $(6+j8)$ ohm per phase connected to a balance 3 phase, 400V supply. Find the line current, power factor, power and total volt-amperes.	10	3

SECTION C

3. Attempt any one part of the following:

Qno.	Question	Marks	CO
a.	Show the condition for resonance in a parallel R-L-C circuit. State the application of series.	10	2
b.	If load draws a current of 10A at 0.8 p.f lagging, when connected to 100 volt supply, calculate the values of real, reactive and apparent powers. And also find the resistance of load.	10	2

