

Roll No: 

--	--	--	--	--	--	--	--	--	--	--	--

**BTECH**  
**(SEM II) THEORY EXAMINATION 2021-22**  
**BASIC ELECTRICAL ENGINEERING**

**Time: 3 Hours****Total Marks: 100****Note:** Attempt all Sections. If you require any missing data, then choose suitably.**SECTION A****1. Attempt all questions in brief.****2\*10 = 20**

Q.No	Questions	CO
(a)	Distinguish between bilateral and unilateral networks.	1
(b)	Three resistances each of 3 ohms are connected in delta. Calculate the value of each branch of equivalent star connection.	1
(c)	The voltage & current through a circuit element are $v = 50 \sin(314t + 550)$ volts, $i = 10 \sin(314t + 3250)$ amps. Find the value of power factor.	2
(d)	Define the phase sequence in three-phase system. What is its importance?	2
(e)	Define mmf and flux density in magnetic circuit.	3
(f)	Write the formulae for efficiency of Transformer. What is the condition for maximum efficiency of transformer?	3
(g)	Why 3 phase induction motor does not run on synchronous speed?	4
(h)	A 4 pole, 1500 rpm, dc generator has a lap wound armature having 240 conductors. If flux per pole is 0.04 wb, calculate the emf generated in the armature.	4
(i)	What is the different type of batteries?	5
(j)	Define Earthing & Neutral Grounding.	5

**SECTION B****2. Attempt any three of the following:****10\*3 = 30**

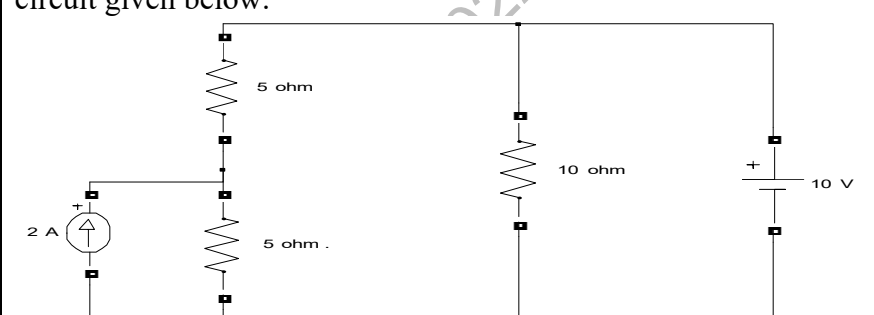
Q.No	Questions	CO
(a)	Find current in all the resistances using superposition theorem in the circuit given below. 	1
(b)	Show that in series resonant circuit $f_1 \cdot f_2 = f_r^2$ where $f_1$ & $f_2$ are half power frequencies & $f_r$ is resonant frequency. Also draw the resonant curve.	2
(c)	A 100 KVA, 2000/200V transformer has full load copper & iron losses of 1800 W & 1500 W respectively. Calculate: (i) The efficiency at half the rated KVA & at unity power factor. (ii) The efficiency at full load & at 0.8 power factor lagging.	3

Roll No: 

--	--	--	--	--	--	--	--	--	--	--	--

**BTECH**  
**(SEM II) THEORY EXAMINATION 2021-22**  
**BASIC ELECTRICAL ENGINEERING**

	(iii) KVA load for maximum efficiency. (iv) value of maximum efficiency.	
(d)	Why single-phase induction motor is not self-starting? Discuss two methods of starting.	4
(e)	Explain Online and Offline UPS with block diagram.	5

**SECTION C**

3. Attempt any *one* part of the following: 10\*1 = 10

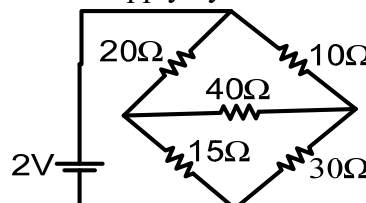
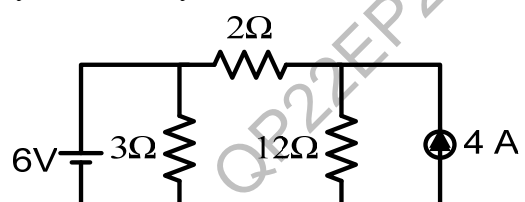
Qno	Questions	CO
(a)	Derive the expression for delta to star transformation and calculate the current supply by 2V source using this transformation. 	1
(b)	Determine the current in 2 ohms resistance in the circuit given below by Nodal analysis. 	1

4. Attempt any *one* part of the following: 10 \*1 = 10

Qno	Questions	CO
(a)	The voltages acting in series are given by: $v_1 = 20 \sin \omega t$ $v_2 = -30 \cos(\omega t - 450)$ $v_3 = 40 \cos(\omega t + 300)$ Find the expression for resultant voltage and also draw the phasor diagram.	2
(b)	Derive the relation between Phase Voltage & Line voltage for Star connected three phase supply system. A 3 phase, 400 volt supply is connected to a 3 phase star connected balanced load. The line current is 20 amps and the power consumed by the load is 12 KW. Calculate the phase impedance of the load, phase current and power factor.	2



Roll No:

--	--	--	--	--	--	--	--	--	--	--	--	--	--	--	--	--	--	--	--

**BTECH**  
**(SEM II) THEORY EXAMINATION 2021-22**  
**BASIC ELECTRICAL ENGINEERING**

5. Attempt any *one* part of the following: 10\*1 = 10

Qno	Questions	CO
(a)	What is auto transformer? What are the advantages and disadvantages of auto transformer over 2-winding transformer? Also give the applications of auto transformer.	3
(b)	Explain the principle of operation of transformer. Also discuss and obtain the equation for induced emf in a two-winding transformer.	3

6. Attempt any *one* part of the following: 10\*1 = 10

Qno	Questions	CO
(a)	A DC shunt machine connected to 230 V supply has resistance of armature as 0.115 Ohm and of field winding as 115 Ohm. Determine the ratio of the speed as generator to the speed as motor with the line current in each cases being 100 A.	4
(b)	Draw and explain the torque-slip characteristics of 3 $\phi$ induction motor. A 12-pole , 3-phase alternator is coupled to an engine running at 500 r.p.m. It supplied a 3-phase induction motor having a full load speed of 1460 r.p.m. Find the percentage slip, frequency of rotor currents and number of poles of the motor.	4

7. Attempt any *one* part of the following: 10\*1 = 10

Qno	Questions	CO
(a)	(i) Explain the purpose and types of earthing. (ii) Explain the various types of wires used in electrical installations.	5
(b)	On the basis of construction, working and necessity, write short notes on the following: (i) SFU, (ii) MCB, (iii) ELCB	5